

The efficient ones... **HUBTEX.**

- Capacities from 0.5 to 12 tonnes
- Multidirectional order picking sideloader
- Multidirectional sideloader with removable order picking platform
- Multidirectional sideloader with order picking device
- Electric two-side order picking platform



Order picking systems

...reliable and effective

Our customers appreciate the HUBTEX machines, especially for the order picking of goods in extremely narrow aisle conditions, since these units can be precisely tailored to the requirements of a warehouse. HUBTEX industrial trucks have to meet the most different requirements during the order picking: Large-volume wooden materials, panels and profiles must be transported highly efficiently and carefully. Owing to the company's industryspecific know-how, HUBTEX is able to develop customized solutions with special optimization effects again and again. Innovation and quality are the keys to success for HUBTEX.

Turn ideas into reality

As soon as an initial idea is fixed, HUBTEX develops a concept which will be coordinated and fine-tuned with you in several steps afterwards. You always benefit from our know-how gained from 30 years of experience in special purpose machinery manufacture.

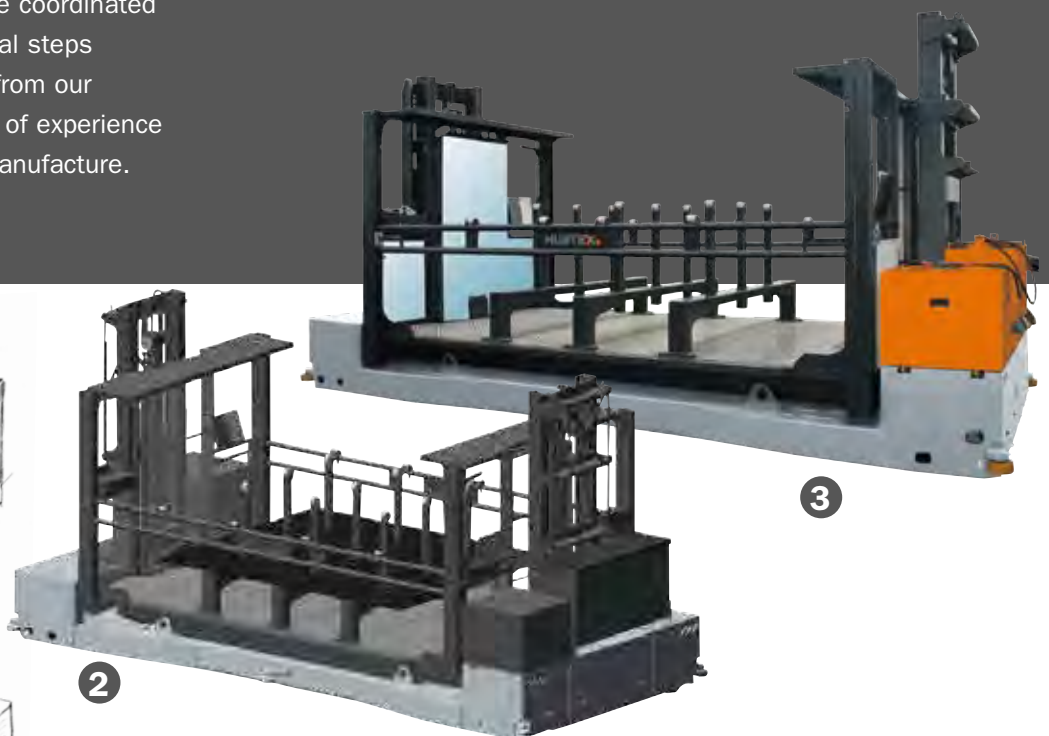
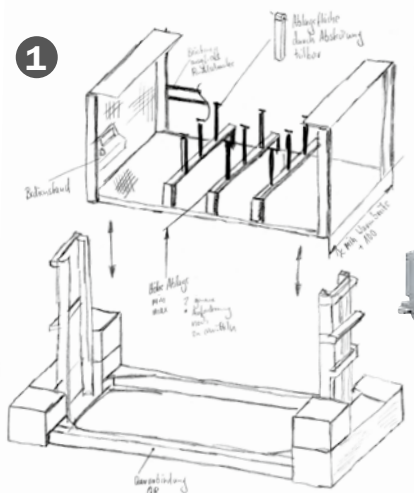

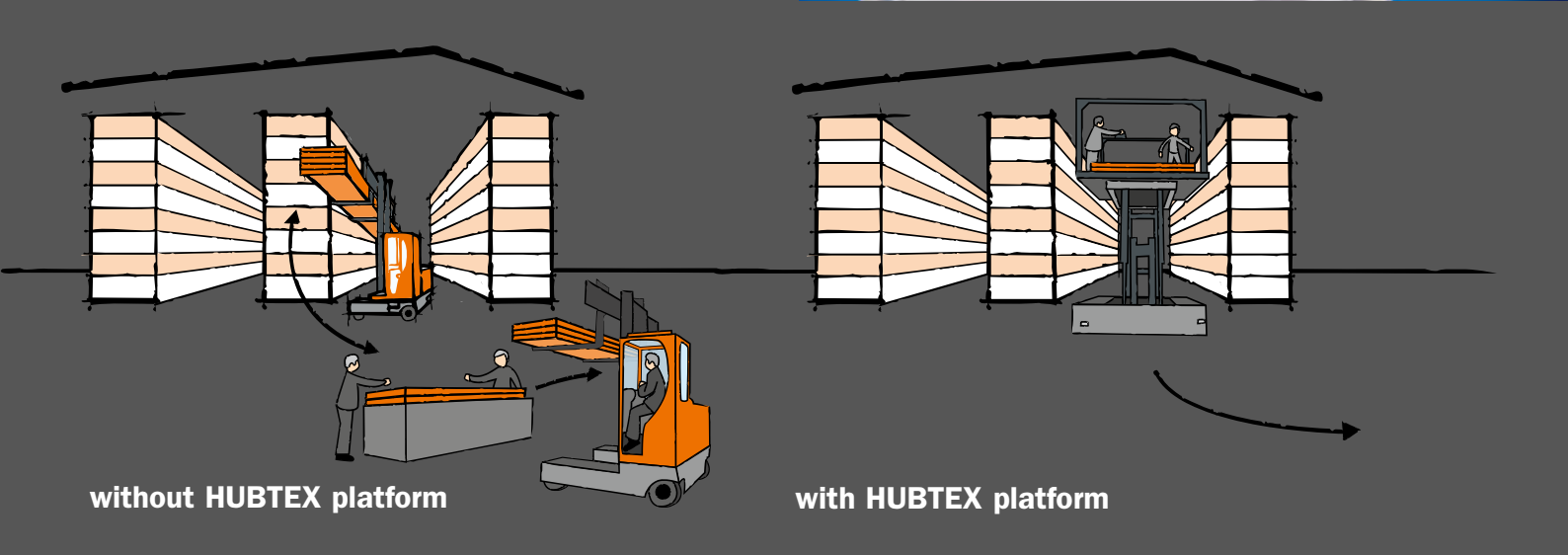

Optimal warehouse capacities

The use of HUBTEX order pickers increases the efficiency in the handling of long and bulky goods in narrow aisles. HUBTEX follows the principle of bringing the operator to the goods here. This reduces the expenditure of work and prevents damage to the goods.

- saving of time of up to 80%
- fast, safe and efficient
- less damage to merchandise/less breakage

Performance overview of the order picking systems



Model	MU-OP	MU-SO	KP	MK	VK	EZK
Material						
Operation (number of persons)						
Manual order picking	✓	✓	✓	✓	–	✓
Semi-automatic order picking	–	✓*	–	–	✓	✓*
Warehousing of complete packs	✓	✓	✓	✓*	✓	✓*
Both-sided rack operation	✓	✓	✓**	✓**	✓	✓
Weights	light	medium to heavy	medium to heavy	medium to heavy	medium to heavy	medium to heavy
Rate of turnover	✓	✓	✓✓	✓✓	✓✓	✓✓✓

*) only possible with special equipment **) only possible in crosswise drive

All HUBTEX trucks are custom-made industrial trucks designed to meet your company's individual requirements for the individual application.

Electric multidirectional order picker

» MU series

The models MU-OP and MU-SO are especially designed for the order picking of long loads in narrow aisles. They are perfectly suited for the order picking of aluminium, plastic or steel profiles. At the same time, these trucks can be used as conventional Electric Multidirectional Sideloaders for the warehousing of complete packs.

- » Fork carriage tilt
for high derated capacities and safe handling at high lifting heights
- » Standard safety devices
for the protection of the driver
- » Electric powered
quiet and environmentally friendly
- » Reduced load arm height
for optimal utilization of the lower storage rack level
- » Load capacities from 1.5 to 6.0 tonnes
- » Combined indoor and outdoor use
- » Guided operation
in narrow aisles or unguided operation
- » Multidirectional steering
for optimal manoeuvrability

- » Ergonomic and liftable standup cabin
with very good all-round visibility and HIT² HUBTEX Information Terminal

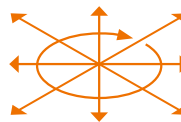

The illustration shows non-standard optional features, especially a reduced truck width due to omission of the battery behind the mast.



› Cabin

The standard cabin with a modern design is mainly characterized by the good accessibility of the cargo and the ergonomic arrangement of all operational controls.

Operation (number of persons)

Application

Load capacity (t)

Lift height (mm)

Aisle width conditional upon load depth or cantilever arm length (mm)

Safety distance in case of guided operation (mm)

› Lift mast

Special know-how is required for the construction of a MU with regard to the lift mast. The lift mast is designed with a high degree of safety, because the compliance with maximum safety standards regarding devices with man-up control is a matter of course for HUBTEX. For this reason, the manufacture is performed by ourselves.

› Options

- › Larger cabin
- › Spreaded fork carrier with reduced height
- › Hydraulic fork adjustment
- › Wire guidance and aisle recognition
- › A full free lift version
- › Bystander protection system
- › Lighting equipment
- › Storage aids





MU-OP

1

Lightweight profiles which are up to 6 metres long

1.0 to 2.5

up to 7000

plus 750

100 per side

MU-SO

1 to 2

Heavy profiles which are up to 12 metres long

up to 5.0

up to 9000

plus 962

100 per side

➤ One-man electric multidirectional order picker

The model MU-OP is designed for one operator for the order picking of lightweight loads. Due to the central arrangement of the cabin in front of the lift mast, this device is perfectly suited for the order picking of light to medium-heavy loads, such as plastic or aluminium profiles.

➤ One-man or two-man electric multidirectional order picker

The model MU-SO with two operators is recommended for the order picking of medium-heavy to heavy loads. The cabins of this model are arranged next to the lift mast. This allows an easy order picking operation by two persons, in particular in case of longer loads. For the warehousing of complete packs, the device is controlled by one driver.

Electric Multidirectional Sideloader with removable order picking platform



» KP series

The model KP can be used as conventional Electric Multidirectional Sideloader for the warehousing of complete packs and for the order picking of individual customer orders with the platform being installed. During the order picking operation, all functions are controlled from the platform. Lift truck and platform form a unit.

This order picker can be used for the one-sided rack operation in narrow aisles and moreover for the two-sided rack operation in unguided aisles. The ready picked goods are safely removed by a separate lift truck or a transfer station.

Operation (number of persons)

1 to 2

Application

Lightweight profiles

Load capacity (t)

1.5 to 7.0

Lift height (mm)

up to 10000

Aisle width (mm)

- One-sided rack operation in the narrow aisle
- Two-sided rack operation
- Safety distance in case of guided operation
- Safety distance in case of unguided operation

Load depth or cantilever arm length plus 1350

Load length plus 1000

150 per side

500 per side





» Load capacities from 1.5 to 7.0 tonnes

» One-sided or two-sided rack operation
One-sided in the narrow aisle or two-sided in the unguided aisle

» All functions are controlled from the platform

» Multidirectional steering for optimal manoeuvrability

» Order picking performance data¹

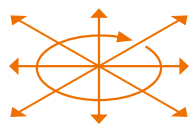

10 to 15 sheets / turn

350 to 400 sheets / day

approx. 1850 sheets / week

approx. 7400 sheets / month

1) In this example you need about 3 hours per day to restock the warehouse.



...reliable and effective

Electric two-side order picking platform

» MK series

The function of the model MK is the warehousing and order picking of doors and frames in pallet racks. This order picking platform is a conventional Electric Multidirectional Sideloader for the warehousing of complete packs and, with man up cabin, for the order picking of individual customer orders. The model MK has a fixed mast.

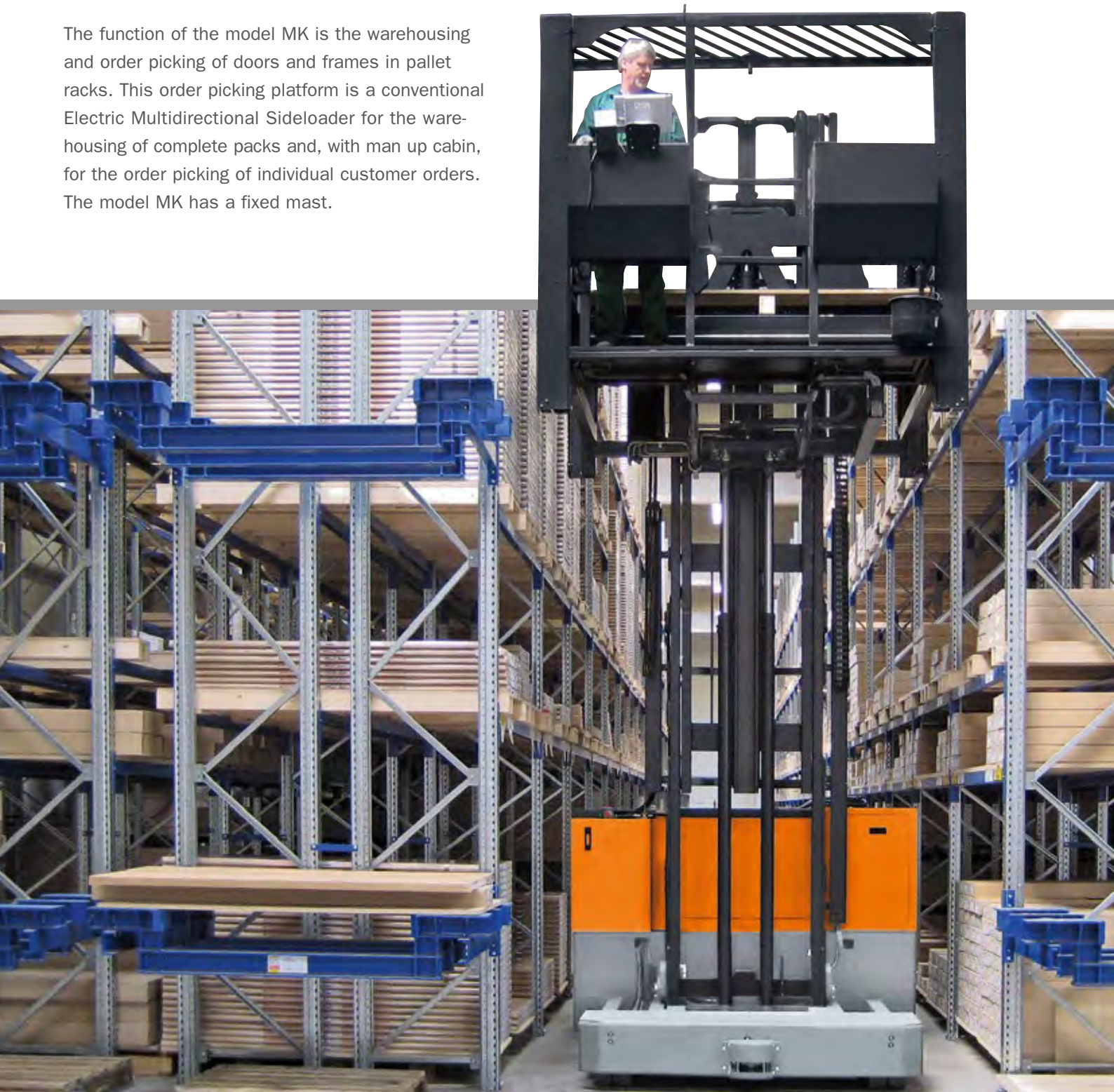

Options

A lifting device for lifting and lowering the load to an ergonomic working height as well as telescopic forks for placing whole door packs into stock and removing them from stock are optionally available. The goods can be picked quickly and easily from either side of the rack aisle.

Storage and removal of full packs



Operation (number of persons)

1

Application

Warehousing and order picking of doors and frames in pallet racks

Load capacity (t)

1.5 to 5.0

Lift height (mm)

up to 7500

Aisle width conditional upon load depth (mm)

plus 400

Safety distance in case of guided operation (mm)

100 per side

Order picking performance data¹

7	positions / turn
150	positions / day
750	positions / week
3000	positions / month

1) In this example you need about 3 hours per day to restock the warehouse.



Electric Multidirectional Sideloader with vacuum suction device

» VK series

The model VK can be used as conventional Electric Multidirectional Sideloader for the warehousing of complete packs and, with vacuum suction device, for the order picking of individual customer orders. With the HUBTEX VK, individual sheets are vacuum lifted

of the rack location and placed onto the fork arms of the lift truck until the order picking operation is finished. Afterwards the picked goods can be loaded directly by means of the lift truck.



Operation (number of persons)

1

Application

Warehousing and order picking of sheets made of different materials which can be lifted using the vacuum cups

Load capacity of the basic unit (t)

3.0 to 10.0

Load capacity of the vacuum suction device (kg)

max. 200

Lift height (mm)

up to 7500

Aisle width conditional upon load depth or cantilever arm length (mm)

plus 1600

Safety distance in case of guided operation (mm)

100 per side



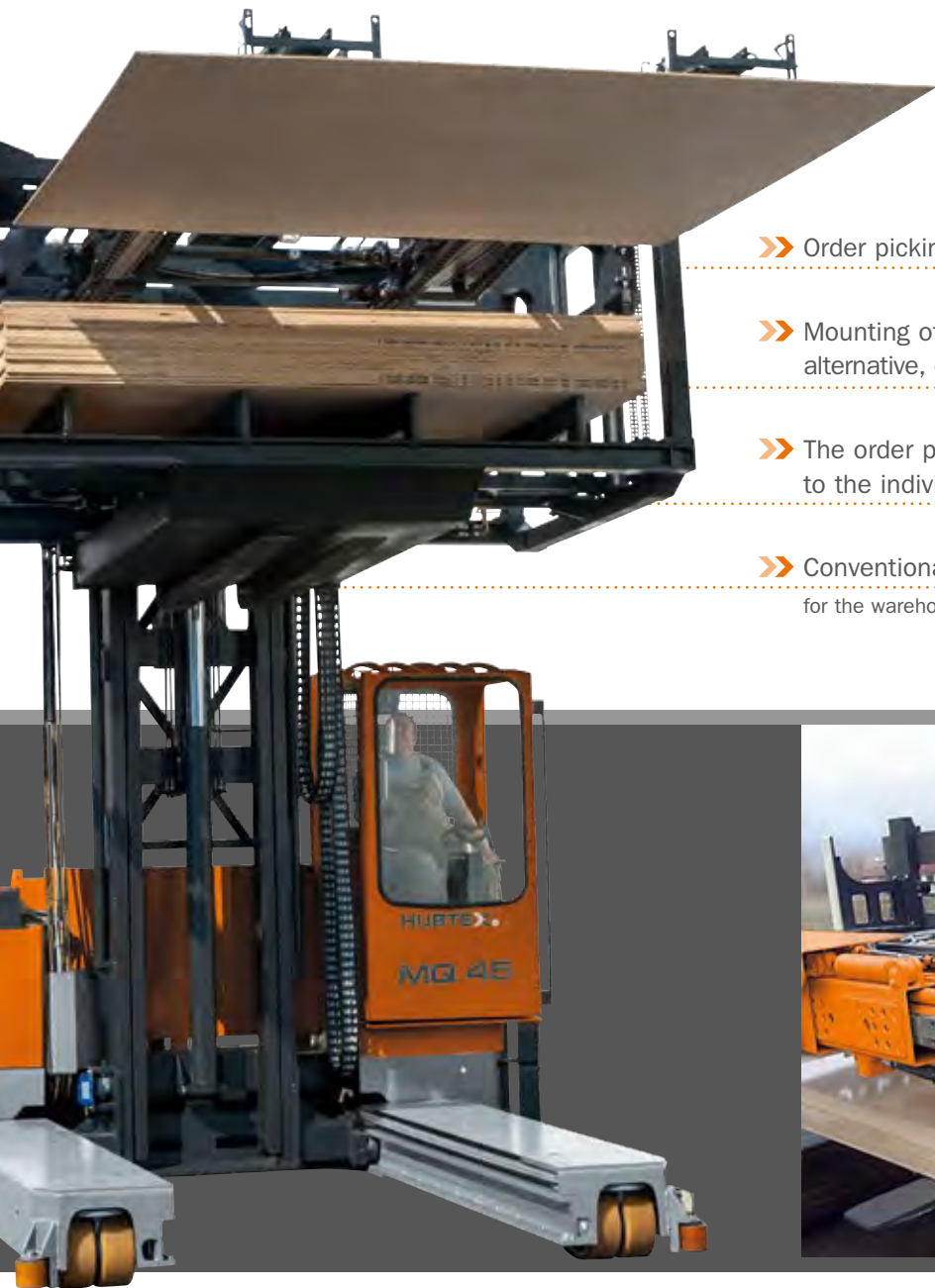

- » Order picking by means of vacuum suction device
- » Mounting of a removable platform which, as an alternative, can be implemented as integrated solution
- » The order picking unit can be customized to the individual requirements
- » Conventional Electric Multidirectional Sideloader for the warehousing of complete packs



» Order picking performance data¹

approx. 70	sheets / turn
approx. 420	sheets / day
approx. 2100	sheets / week
approx. 8400	sheets / month

1) On average 27 sheets are taken into consideration for one order-picking operation. Approximately 2 hours per day are taken into consideration for refilling the racks.

» Integrated or removable vacuum suction device

As integrated version, the model VK is equipped with a telescopic suction device which has been firmly installed on the vehicle and which can be folded down for the order picking operation. Alternatively, the equipment can be fitted with a removable suction device. This suction device is such that it can also be fitted on various other HUBTEX vehicles that have a prepared receptacle for the suction device.

Electric two-side order picking platform with two mast or scissor lift

» EZK series

Model EZK trucks are pure order picking platforms. Whether as two mast or scissor lift version – order picking of up to 8 m long profiles or sheet stock which is between 600 mm and 2100 mm deep can be performed with these systems.

The goods can be easily picked from either side of the rack aisle. A load shifting device is optionally available for both models to facilitate the removal of the orderpicked goods by a separate lift truck.

Operation (number of persons)	1 to 2
Application	Order picking of different load sizes at a very high rate of turnover
Load capacity (t)	2.0 to 12.0
Lift height (mm)	up to 8500
Aisle width conditional upon load depth (mm)	at least 2500
Safety distance in case of guided operation (mm)	150 per side



» Order picking performance data¹

3	sheets / turn
450	sheets / day
2250	sheets / week
9000	sheets / month

¹ In this example you need about 3 hours per day to restock the warehouse.



➤ **Two mast order picking platform**

The two mast version of the HUBTEX order picking platform is especially characterized by its low platform height. This results in advantages for the handling of the lowest rack level.

➤ **Scissor lift order picking platform**

In contrast to the two mast version, the advantage of the scissor lift version is its shorter overall length. For this reason, order picking platforms with scissor lift system can be operated in significantly narrower spaces. Thus, the width of the transfer aisle can be reduced.

➤➤ **Two lift masts**

➤➤ **Low platform height**

with a minimum of 460 mm at a high lifting height



➤➤ **Scissor lift system**

➤➤ **Short chassis length**

at a maximum load length plus 600 mm driver station per side



» EZK equipment versions in detail

HUBTEX offers a large number of different equipment versions to meet your requirements in the best possible manner.



» Operation

The customer can choose between different versions for the operation of the truck, it can be equipped with one or two control stations. The advantage of the equipment version with two control stations per truck is the best possible overview in each driving direction. Moreover, the operator can choose between two different arrangements of the control station. Standing, in main driving direction or seated, facing the load (only in connection with a bystander protection system).



➤ **Telescopic tables**

For the transfer of the picked goods, HUBTEX two-side order pickers can be optionally equipped with telescopic tables. In this way, a finished pack can be passed on to a transfer station on both sides of the truck.

➤ **Scissor lifting table**

For the ergonomic order picking of goods, the HUBTEX order picking platform can be optionally equipped with a scissor lifting table on the platform. Thus, the stacking height on the vehicle can be individually adjusted. In this way, the operator can avoid unnecessary bending or stooping.



➤➤ Telescopic tables
for the storage and removal of full packs

➤➤ Telescopic tables can be individually controlled
optionally with 2- or 4-fold reach

Order picking special-purpose trucks

» Tailored to your requirements

Due to the modular design of our trucks, different application areas can be combined with each other. An example is the MU-SO with two turnable cabins and attached vacuum suction device.

» Fully equipped HUBTEX MU-SO
for the order picking of long profiles

» Adequate Electric Multidirectional Sideloader
for the warehousing of complete packs

» Adjustable load limit stop
for different load lengths

» Vacuum suction device with one-man operation

» Turnable man-up cabin
with HUBTEX safety equipment
in case of two-man operation



This vehicle is used as one-man version with vacuum suction device for order picking operations. For the order picking of laminates, the vacuum suction device is folded up and the cabins are turned forward. Afterwards two operators can perform the manual order picking of laminates.

Your HUBTEX moves on and on

Who should understand your HUBTEX better than we do? Apart from excellent service, HUBTEX offers you long-term investment security which is indeed “the manufacturer’s know-how”.



➤ More HUBTEX

Excellent trained technicians whose knowledge and know-how always reflects the latest state of the art.

➤ More service

- Exactly calculable maintenance costs due to factory guidelines with regard to service times.
- No unnecessary time required for fault finding due to latest diagnostic tools.

- Highest quality due to the exclusive use of original spare parts.
- Fastest possible solution of problems by comprehensive factory support.
- Technicians have the welder's qualification certificate which allows them to perform safety-relevant work tasks on their own.

➤ More value

- Due to the exclusive use of original spare parts, your truck remains an original HUBTEX.
- Our service experts offer you maximum transparency regarding the development of your maintenance costs.
- Customized maintenance concepts provide you with a clearly calculable cost structure.
- On request, we analyze your present maintenance costs and show you where potential for savings exists.

➤ More safety

You can be sure that all safety-related equipment of your truck is checked by competent, specialized technicians according to the latest guidelines at least once per year.

HUBTEX at your disposal in more than 60 countries all over the world.



HUBTEX Maschinenbau GmbH & Co. KG

Industriepark West

Werner-von-Siemens-Str. 8

36041 Fulda, Germany

Telephone: +49-661-8382-0

Fax: +49-661-8382-120

info@hubtex.com

www.hubtex.com



**Further HUBTEX products
at a glance:**

- Electric Multidirectional Sideloaders
- Diesel / Gas Fourway Sideloaders
- Sideloaders
- Glass Transport Systems
- Heavy-Duty Transport Vehicles
- Fork-Lift Reach Trucks
- Special-Purpose Vehicles
- Second-Hand and Rental Equipment